

item	type	637.310
port size		G 1/4
medium		compressed air, filtered 5µm + oil-free <sup>(1)</sup> , neutral gases
gauge port size		for feedback pressure
description		air line regulator for feedback systems
		e.g. together with DRI.33 ... 88
mounting		arbitrary
supply pressure		Pe max. 16 bar
reduced pressure		0,2 - 7 bar
air consumption		3 - 6 l/min
medium- and ambient temperature		-10 to 60 °C (other temperature ranges available upon request)
fixing		panel mounting, mounting diameter ø20,5; bracket
weight		0,850 kg

- <sup>(1)</sup> quality class 1 to ISO 8573-1 (Remaining oil content 0,01 mg/m<sup>3</sup>), fine filter (register 6)



**replacement parts**

no.	description	material
1	body	zinc - Z 410
2	spring cage	zinc - Z 410
3	diaphragm	FPM
4	valve cone	FPM
5	spring	st.-galvanized
6	spring	stainless steel
7	O-ring 16x2	FPM
8	bonnet	POM

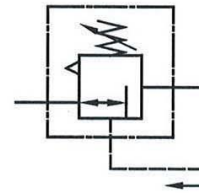

series 3

**application information**

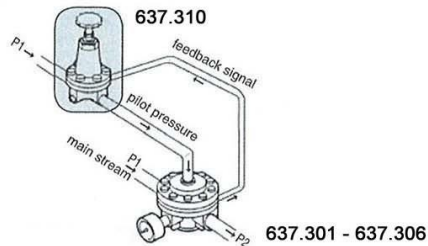

dimensions (mm)

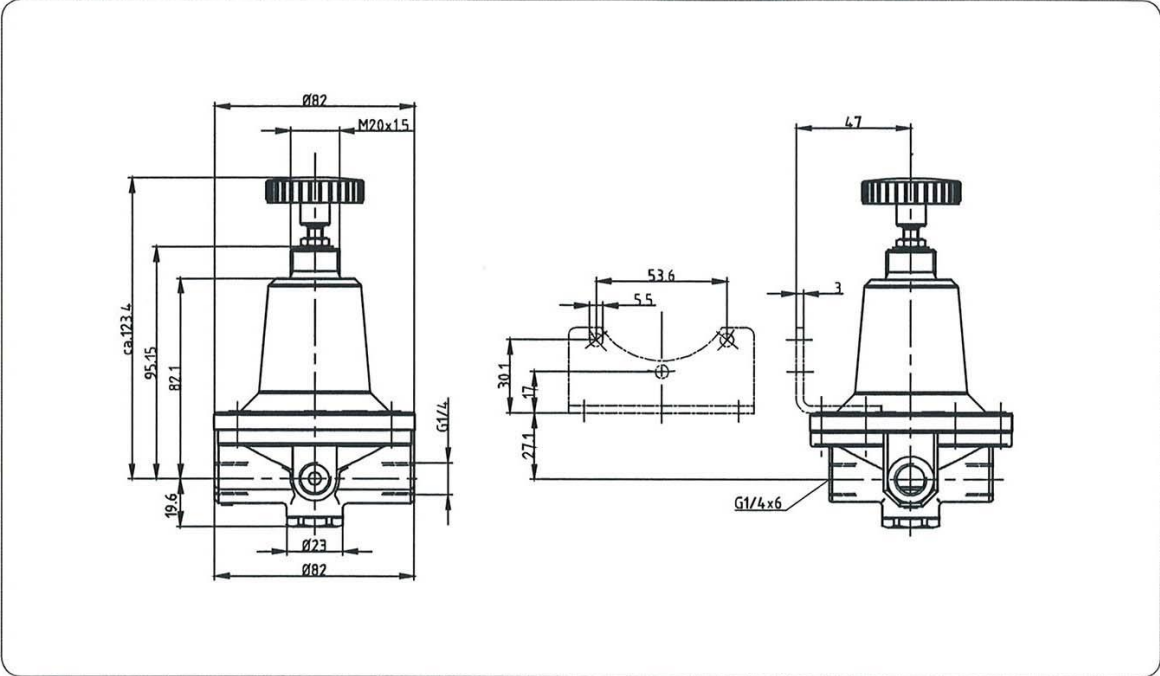

flow characteristics

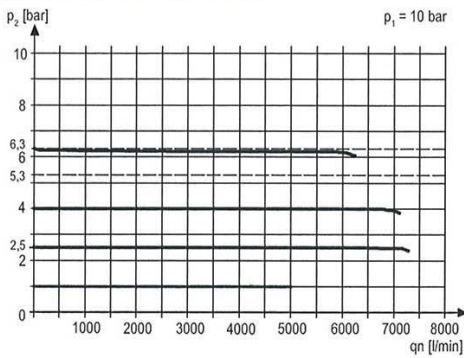

accessories

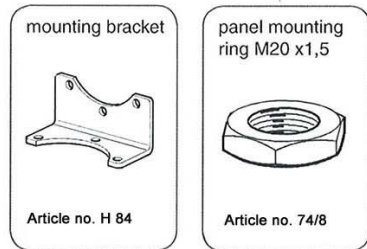

Applications: Conventional pilot

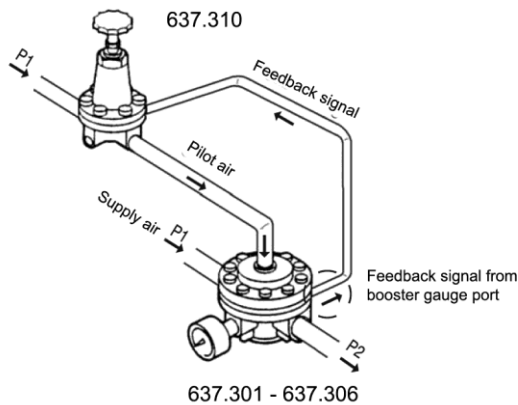

Applications: Feedback pilot

